

## Pyrotechnic Device Disposal

### Disposal of Deployable Devices and Pyrotechnic Devices That are Undeployed/Inoperative

**NOTE:** All inoperative air bag modules and safety belt pretensioners have been placed on the Mandatory Return List. All discolored or damaged air bag modules must be treated the same as any inoperative live air bag being returned.

1. Depower the Supplemental Restraint System (SRS). For additional information, refer to [Supplemental Restraint System \(SRS\) Depowering and Repowering](#) in the General Procedures portion of this section.
2. Remove the undeployed/inoperative device. For additional information, refer to the appropriate procedure in this section or [Section 501-20A](#).
3. **NOTE:** When installing a new air bag module, a prepaid return postcard is provided with the replacement air bag module. The serial number for the new part and the Vehicle Identification Number (VIN) must be recorded and sent to Ford Motor Company.

If installing a new air bag module, record the necessary information and return the inoperative air bag module to Ford Motor Company.

### Disposal of Deployable Devices and Pyrotechnic Devices That Are Deployed

1. Depower the [SRS](#). For additional information, refer to [Supplemental Restraint System \(SRS\) Depowering and Repowering](#) in the General Procedures portion of this section.
2. Remove the deployed device. For additional information, refer to the appropriate procedure in this section or [Section 501-20A](#).
3. **NOTE:** If a dual stage driver or passenger air bag module has deployed due to a crash event, the air bag module requires manual deployment to make sure both stages have deployed before scrapping the vehicle or disposing of the air bag module. To determine if a vehicle is equipped with dual stage driver or passenger air bag modules, refer to the Description and Operation portion of this section.

Dispose of the deployed device in the same manner as any other part to be scrapped.

### Disposal of Deployable Devices and Pyrotechnic Devices That Require Manual Deployment

1. Safety and environmental concerns require consideration and treatment of restraints system deployable and pyrotechnic devices when disposing of vehicles, deployable devices or pyrotechnic devices. Deploying deployable and pyrotechnic devices before scrapping a vehicle or the device eliminates the potential for hazardous exposures or reactions during processing. If special handling procedures are followed, deployable and pyrotechnic devices can be deployed safely and recycled with the vehicle, shipped separately to a recycling facility or disposed of safely.

**NOTE:** To determine the deployable devices a vehicle is equipped with, refer to the Description and Operation portion of this section.

A vehicle equipped with any of the following deployable devices requires manual deployment of the devices before scrapping the vehicle or component. For additional information, refer to the appropriate portion of this procedure.

- Driver air bag module

- Passenger air bag module
- Seat side air bag modules
- Safety Canopy® modules
- Side air curtain modules

2. **NOTE:** To determine the pyrotechnic devices a vehicle is equipped with, refer to the Description and Operation portion of this section.

A vehicle equipped with any of the following pyrotechnic devices requires manual deployment of the devices before scrapping the vehicle or component. For additional information, refer to the appropriate portion of this procedure.

- Safety belt buckle pretensioners
- Safety belt retractor pretensioners
- Adaptive load-limiting retractors
- Deployable steering column

3. **NOTE:** To determine if a vehicle is equipped with dual stage driver or passenger air bag modules, refer to the Description and Operation portion of this section.

If a dual stage driver or passenger air bag module has deployed due to a crash event, the air bag module requires manual deployment to make sure both stages have deployed before scrapping the vehicle or disposing of the air bag module. For additional information, refer to Driver Air Bag Module, Passenger Air Bag Module and Seat Side Air Bag Modules — Remote Deployment in this procedure.

### **Driver Air Bag Module, Passenger Air Bag Module and Seat Side Air Bag Modules — Remote Deployment**



**WARNING:** Never probe the electrical connectors on air bag, Safety Canopy® or side air curtain modules. Failure to follow this instruction may result in the accidental deployment of these modules, which increases the risk of serious personal injury or death.



**WARNING:** Always carry or place a live air bag module with the air bag and deployment door/trim cover/tear seam pointed away from the body. Do not set a live air bag module down with the deployment door/trim cover/tear seam face down. Failure to follow these instructions may result in serious personal injury in the event of an accidental deployment.



**WARNING:** Always carry or place a live Safety Canopy®, or side air curtain module, with the module and tear seam pointed away from your body. Failure to follow this instruction may result in serious personal injury or death in the event of an accidental deployment.



**WARNING:** Deploy all supplemental restraint system (SRS) devices (air bags, pretensioners, load limiters, etc.) outdoors with all personnel at least 9.14 meters (30 feet) away to make sure of personal safety. Due to the loud report which occurs when an SRS device is deployed, hearing protection is required. Failure to follow these instructions may result in serious personal injury.

**NOTE:** For air bag modules with multiple loops, all the loops on the air bag module must be deployed.

**NOTE:** Some driver and passenger front air bags have 2 deployment stages. After a collision it is possible that Stage 1 has deployed and Stage 2 has not.

If a front air bag module has deployed, it is **mandatory** that the front air bag module be remotely deployed using the appropriate air bag disposal procedure.

**NOTE:** A typical air bag disposal is shown that is similar for all vehicles.

**All driver, passenger and seat side air bag modules**

1. Make a container to house the air bag module for deployment.
  - **NOTE:** The tires must be of sufficient size to accommodate the air bag module.

Obtain a tire and wheel assembly and an additional 4 tires (without wheels) of the same size.

- With the tire and wheel assembly on the bottom, stack the tires.
- Securely tie all of the tires together.

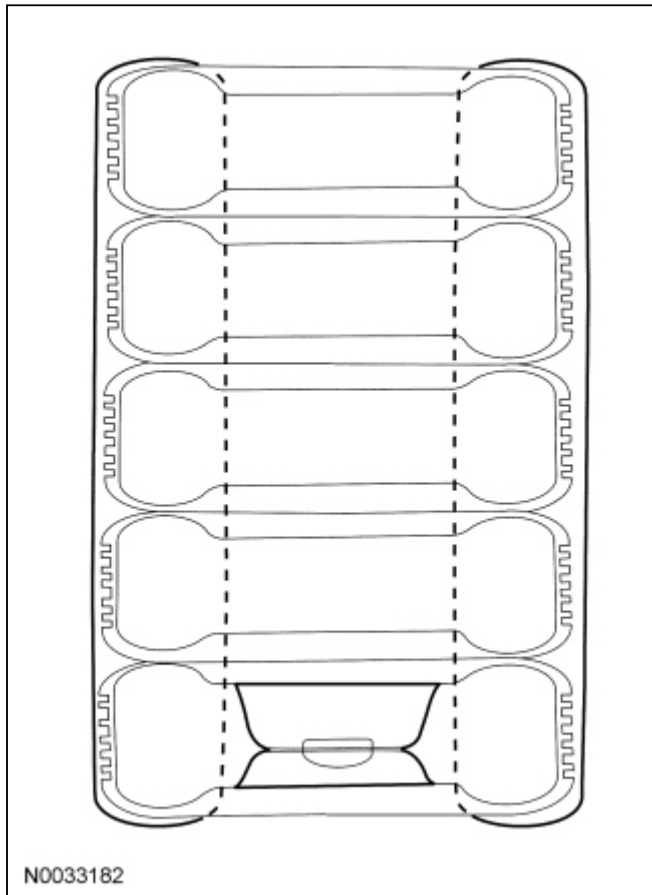

2. Depower the [SRS](#). For additional information, refer to [Supplemental Restraint System \(SRS\) Depowering and Repowering](#) in the General Procedures portion of this section.
3. Remove the air bag module. For additional information, refer to the appropriate procedure in this section.
4. **NOTE:** If the air bag module does not have a hard-wired pigtail, it will be necessary to cut the wires and connector(s) from the vehicle wire harness and reconnect to the air bag module.

Cut each of the air bag module wires near the electrical connector that connects to the vehicle wire harness.

5. Remove any sheathing (if present) and strip the insulation from the ends of the cut wires.
6. **NOTE:** Typical driver air bag module with 2 loops shown, other air bag modules with multiple loops similar.

For air bag modules with multiple loops, twist together a wire from each loop then repeat for the remaining wires from each loop.

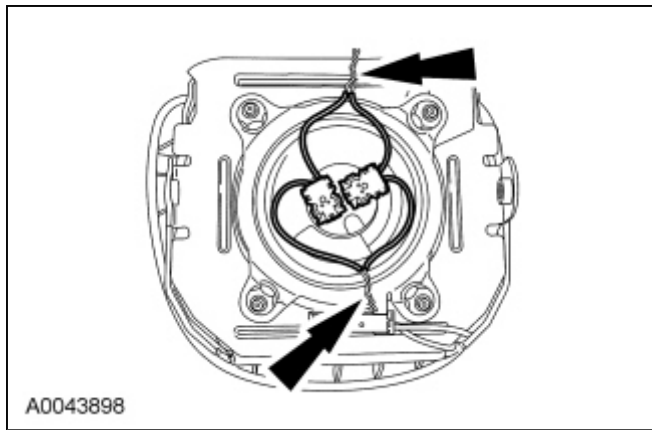

7. Make a jumper harness to deploy the air bag module.
  - Obtain 2 wires (20 gauge minimum) at least 9.14 m (30 ft) long and strip both ends of each wire.
  - At one end of the jumper harness, connect the wires together.
8. Using the end of the jumper harness where the wires are not connected together, attach each wire of the jumper harness to each wire of the air bag module or to the twisted-together wires if multiple loops. Use tape or other insulating material to make sure that the leads do not make contact with each other.

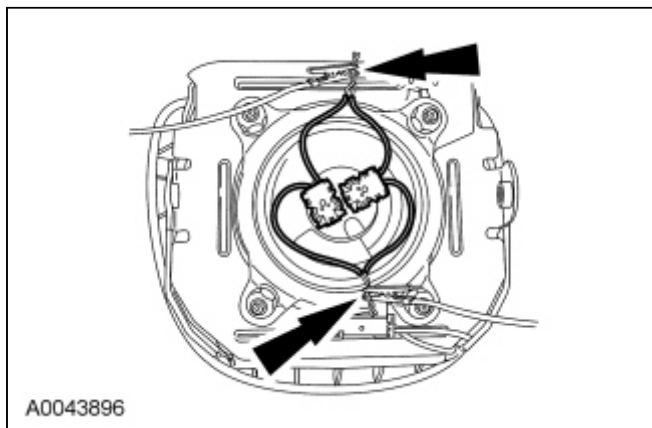

### Driver air bag modules

9. **NOTE:** Make sure to maintain the connections to the air bag module.

With the stack of tires upright and the wheel on the bottom, carefully place the driver air bag module, with the trim cover facing up, on the wheel.

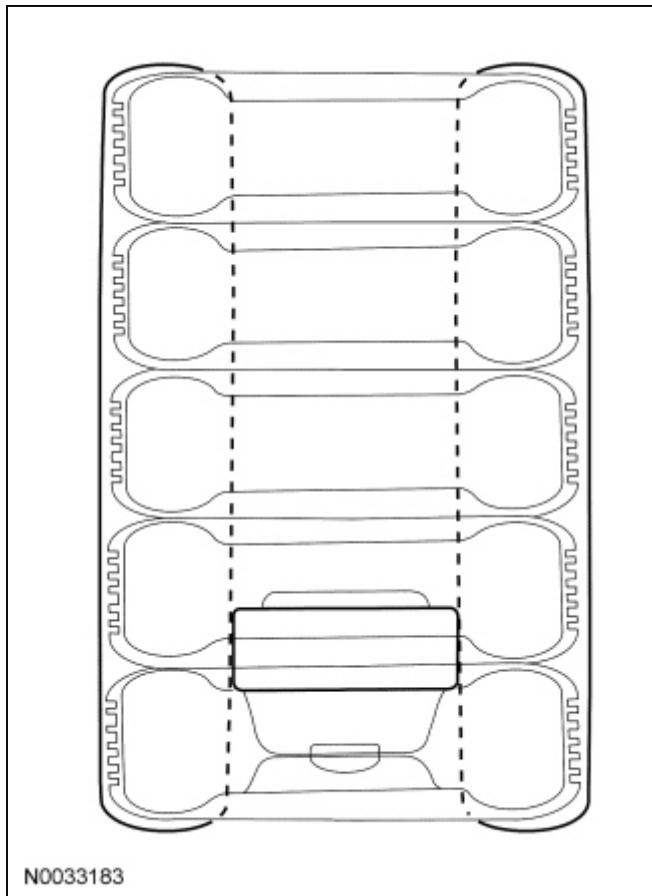

### Passenger and seat side air bag modules

10. **NOTE:** Make sure to maintain the connections to the air bag module.

Tip the stack of tires on its side and place the air bag module inside the center tire, making sure that there are 2 tires beneath the tire containing the air bag module and 2 tires (including the tire and wheel assembly) above the tire containing the air bag module.

11. Place the tire stack upright, with the wheel on top.

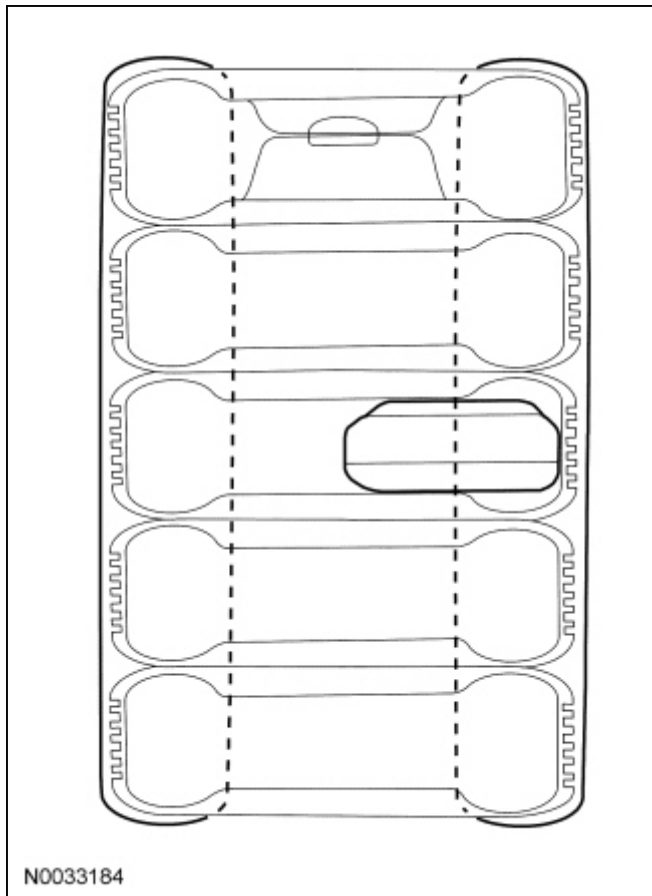

#### All driver, passenger and seat side air bag modules

12. Remain at least 9.14 m (30 ft) away from the air bag module.
13. From the end of the jumper harness that is not connected to the air bag module, disconnect the 2 wires of the jumper harness from each other.
14. Deploy the air bag module by touching the ends of the 2 wires of the jumper harness to the terminals of a 12-volt battery.
15. To allow for cooling, wait at least 10 minutes before approaching the deployed air bag module.
16. Dispose of the deployed air bag module in the same manner as any other part to be scrapped.

#### Safety Belt Buckle Pretensioners, Safety Belt Retractor Pretensioners and Adaptive Load Limiting Safety Belt Retractors — Remote Deployment

 **WARNING:** Never disassemble or tamper with safety belt buckle/retractor pretensioners or adaptive load limiting retractors or probe the electrical connectors. Failure to follow this instruction may result in the accidental deployment of the safety belt pretensioners or adaptive load limiting retractors which increases the risk of serious personal injury or death.

 **WARNING:** Deploy all supplemental restraint system (SRS) devices (air bags, pretensioners, load limiters, etc.) outdoors with all personnel at least 9.14 meters (30 feet) away to make sure of personal safety. Due to the loud report which occurs when an SRS device is deployed, hearing protection is required. Failure to follow these instructions may result in serious personal injury.

**NOTE:** A typical safety belt buckle and retractor disposal is shown that is similar for all vehicles.

1. Make a container to house the safety belt buckle or retractor for deployment.
  - **NOTE:** The tires must be of sufficient size to accommodate the safety belt buckle or retractor.

Obtain a tire and wheel assembly and an additional 4 tires (without wheels) of the same size.

  - With the tire and wheel assembly on the bottom, stack the tires.
  - Securely tie all of the tires together.

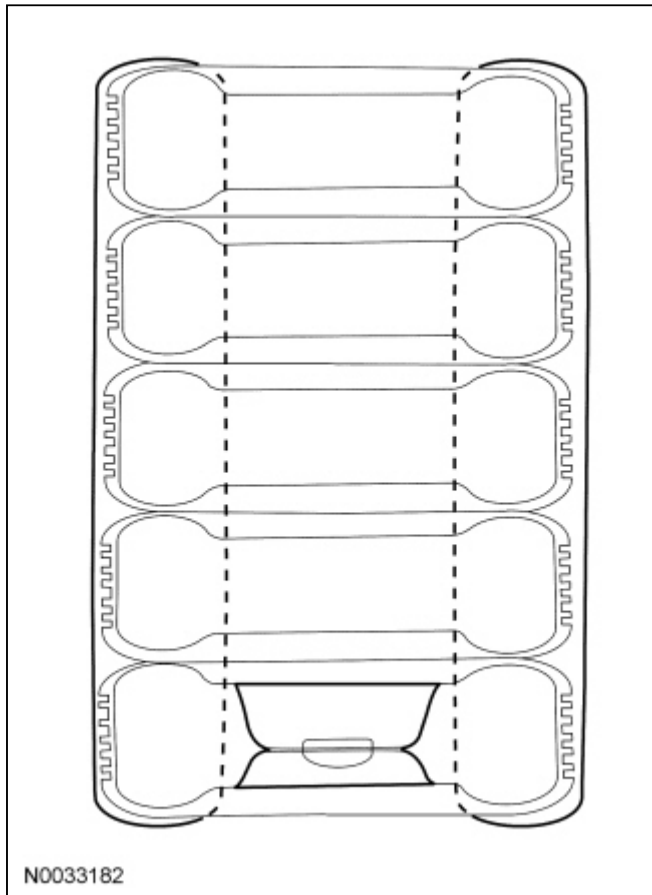

2. Depower the [SRS](#). For additional information, refer to [Supplemental Restraint System \(SRS\) Depowering and Repowering](#) in the General Procedures portion of this section.
3. Remove the safety belt buckle or retractor. For additional information, refer to the appropriate procedure in [Section 501-20A](#).
  - When deploying a safety belt buckle pretensioner, install a nut and bolt of sufficient length and of the same diameter as was used to retain it to the seat.
4. **NOTE:** If the safety belt buckle or retractor does not have a hard-wired pigtail, it will be necessary to cut the wires and connector(s) from the vehicle wire harness and reconnect to the safety belt buckle or retractor.
 

Cut each of the safety belt buckle or retractor wires near the electrical connector that connects to the vehicle wire harness.
5. Remove any sheathing (if present) and strip the insulation from the ends of the cut wires.
6. Make a jumper harness to deploy the safety belt buckle or retractor.
  - Obtain 2 wires (20 gauge minimum) at least 9.14 m (30 ft) long and strip both ends of each wire.
  - At one end of the jumper harness, connect the wires together.
7. **NOTE:** Typical safety belt retractor pretensioner shown, other safety belt buckle pretensioners and load-limiting retractors similar.

Using the end of the jumper harness that the wires are not connected together, attach each wire of the jumper harness to each wire of the safety belt buckle or retractor. Use tape or other insulating material to

make sure that the leads do not make contact with each other.

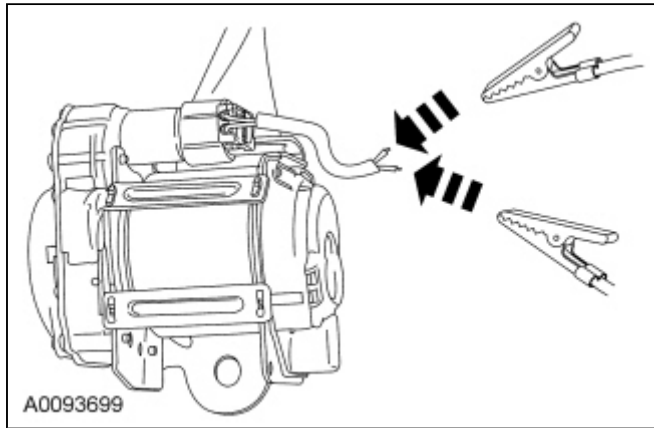

8. **NOTE:** Make sure to maintain the connections to the safety belt buckle or retractor.

Tip the stack of tires on its side and place the safety belt buckle or retractor inside the center tire, making sure that there are 2 tires beneath the tire containing the safety belt buckle or retractor and 2 tires (including the tire and wheel assembly) above the tire containing the safety belt buckle or retractor.

9. Place the tire stack upright, with the wheel on top.

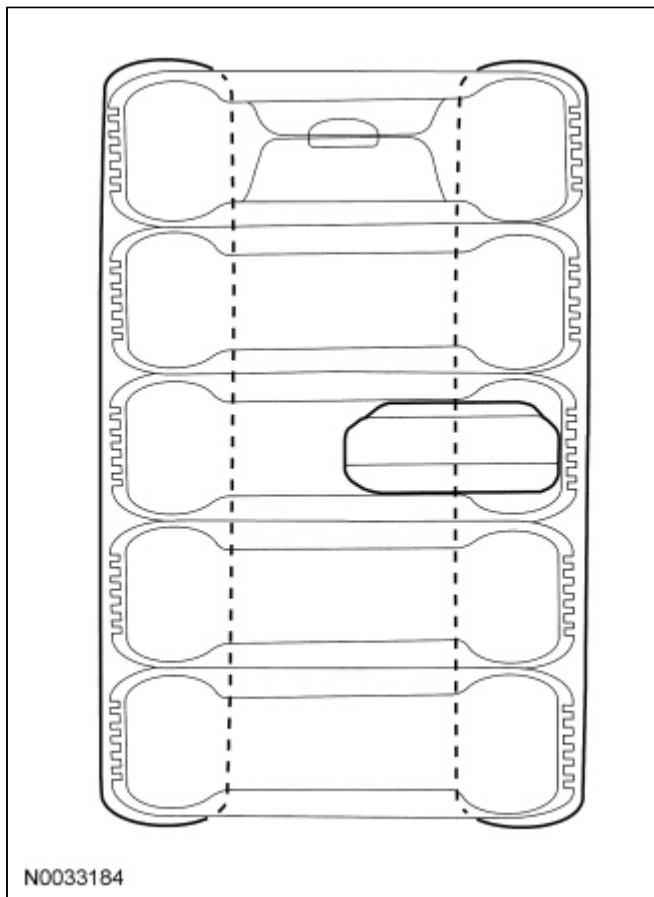

10. Remain at least 9.14 m (30 ft) away from the safety belt buckle or retractor.
11. From the end of the jumper harness that is not connected to the safety belt buckle or retractor, disconnect the 2 wires of the jumper harness from each other.
12. Deploy the safety belt buckle or retractor by touching the ends of the 2 wires of the jumper harness to the terminals of a 12-volt battery.
13. To allow for cooling, wait at least 10 minutes before approaching the deployed safety belt buckle or



retractor.

14. Dispose of the deployed safety belt buckle or retractor in the same manner as any other part to be scrapped.

### Safety Belt Buckle Pretensioners, Safety Belt Retractor Pretensioners and Load Limiting Safety Belt Retractors — In-Vehicle Deployment



**WARNING:** Never disassemble or tamper with safety belt buckle/retractor pretensioners or adaptive load limiting retractors or probe the electrical connectors. Failure to follow this instruction may result in the accidental deployment of the safety belt pretensioners or adaptive load limiting retractors which increases the risk of serious personal injury or death.



**WARNING:** Deploy all supplemental restraint system (SRS) devices (air bags, pretensioners, load limiters, etc.) outdoors with all personnel at least 9.14 meters (30 feet) away to make sure of personal safety. Due to the loud report which occurs when an SRS device is deployed, hearing protection is required. Failure to follow these instructions may result in serious personal injury.

**NOTE:** A typical safety belt buckle and retractor disposal is shown that is similar for all vehicles.

1. Depower the [SRS](#). For additional information, refer to [Supplemental Restraint System \(SRS\) Depowering and Repowering](#) in the General Procedures portion of this section.
2. Access the safety belt buckle or retractor electrical connectors. For additional information, refer to [Section 501-20A](#).
3. Cut each of the safety belt buckle or retractor wires, leaving at least 101.6 mm (4 in) to work with.
4. Remove any sheathing (if present) and strip the insulation from the ends of the cut wires.
5. Make a jumper harness to deploy the safety belt buckle or retractor.
  - Obtain 2 wires (20 gauge minimum) at least 9.14 m (30 ft) long and strip both ends of each wire.
  - At one end of the jumper harness, connect the wires together.
6. **NOTE:** Typical safety belt retractor pretensioner shown, other safety belt buckle pretensioners and load-limiting retractors are similar.

Using the end of the jumper harness that the wires are not connected together, attach each wire of the jumper harness to each wire of the safety belt buckle or retractor. Use tape or other insulating material to make sure that the leads do not make contact with each other.

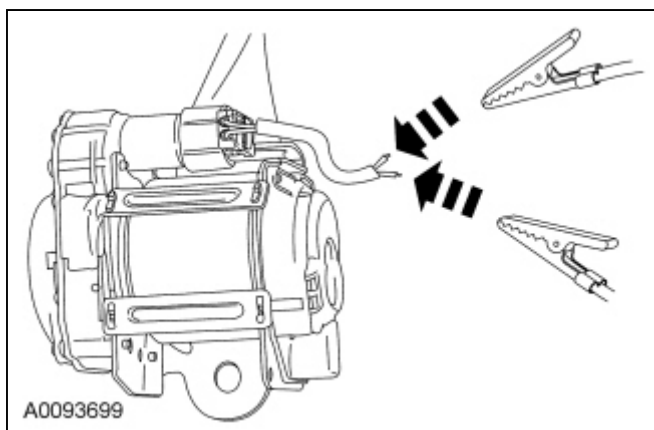

7. Remain at least 9.14 m (30 ft) away from the safety belt buckle or retractor.
8. From the end of the jumper harness that is not connected to the safety belt buckle or retractor, disconnect

the 2 wires of the jumper harness from each other.

9. Deploy the safety belt buckle or retractor by touching the ends of the 2 wires of the jumper harness to the terminals of a 12-volt battery.
10. To allow for cooling, wait at least 10 minutes before approaching the deployed safety belt buckle or retractor.
11. Dispose of the deployed safety belt buckle or retractor in the same manner as any other part to be scrapped.

### Safety Canopy® Modules and Side Air Curtain Modules — In-Vehicle Deployment



**WARNING:** Deploy all supplemental restraint system (SRS) devices (air bags, pretensioners, load limiters, etc.) outdoors with all personnel at least 9.14 meters (30 feet) away to make sure of personal safety. Due to the loud report which occurs when an SRS device is deployed, hearing protection is required. Failure to follow these instructions may result in serious personal injury.

**NOTE:** The Safety Canopy® module deployment for a scrapped vehicle will occur in its installed position in the vehicle.

**NOTE:** A typical Safety Canopy® module disposal is shown that is similar for all vehicles.

1. Depower the [SRS](#). For additional information, refer to [Supplemental Restraint System \(SRS\) Depowering and Repowering](#) in the General Procedures portion of this section.
2. Access the Safety Canopy®/side air curtain module electrical connectors. For additional information, refer to the appropriate procedure in this section.
3. Cut each of the Safety Canopy®/side air curtain module wires leaving at least 101.6 mm (4 in) to work with.
4. Remove any sheathing (if present) and strip the insulation from the ends of the cut wires.
5. **NOTE:** Typical Safety Canopy®/side air curtain module with 2 loops shown, other Safety Canopy®/side air curtain modules with 2 loops are similar.

For Safety Canopy®/side air curtain modules with multiple loops, twist together a wire from each loop then repeat for the remaining wires from each loop.

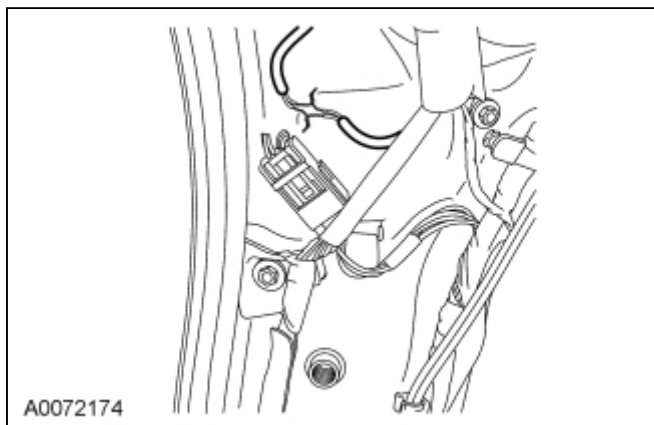

6. Make a jumper harness to deploy the Safety Canopy®/side air curtain module.
  - Obtain 2 wires (20 gauge minimum) at least 9.14 m (30 ft) long and strip both ends of each wire.
  - At one end of the jumper harness, connect the wires together.

- Using the end of the jumper harness where the wires are not connected together, attach each wire of the jumper harness to each wire of the Safety Canopy®/side air curtain module or to the twisted-together wires if multiple loops. Use tape or other insulating material to make sure that the leads do not make contact with each other.

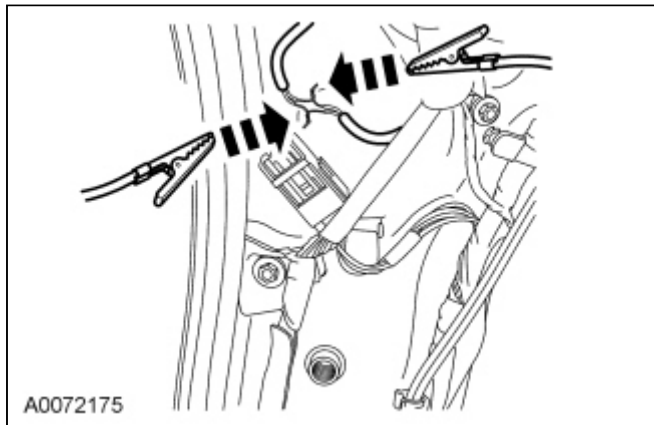

- From the end of the jumper harness that is not connected to the Safety Canopy®/side air curtain module, disconnect the 2 wires of the jumper harness from each other.
- Deploy the Safety Canopy®/side air curtain module by touching the ends of the 2 wires of the jumper harness to the terminals of a 12-volt battery.
- To allow for cooling, wait at least 10 minutes before approaching the deployed Safety Canopy®/side air curtain module.
- Dispose of the deployed Safety Canopy®/side air curtain module in the same manner as any other part to be scrapped.

### Deployable Steering Column — In-Vehicle Deployment



**WARNING:** Deploy all supplemental restraint system (SRS) devices (air bags, pretensioners, load limiters, etc.) outdoors with all personnel at least 9.14 meters (30 feet) away to make sure of personal safety. Due to the loud report which occurs when an SRS device is deployed, hearing protection is required. Failure to follow these instructions may result in serious personal injury.

- Depower the [SRS](#). For additional information, refer to [Supplemental Restraint System \(SRS\) Depowering and Repowering](#) in the General Procedures portion of this section.

- NOTE:** It may be necessary to lower or remove the deployable steering column from the instrument panel to access the deployable steering column electrical connector.

Access the deployable steering column electrical connector.

- NOTE:** If the deployable steering column does not have a hard-wired pigtail, it will be necessary to cut the wires and connector(s) from the vehicle wire harness and reconnect to the deployable steering column.

Cut each of the deployable steering column wires, leaving at least 101.6 mm (4 in) to work with.

- Remove any sheathing (if present) and strip the insulation from the ends of the cut wires.
- Make a jumper harness to deploy the deployable steering column.
  - Obtain 2 wires (20 gauge minimum) at least 9.14 m (30 ft) long and strip both ends of each wire.
  - At one end of the jumper harness, connect the wires together.
- Using the end of the jumper harness where the wires are not connected together, attach each wire of the jumper harness to each wire of the deployable steering column. Use tape or other insulating material to

make sure that the leads do not make contact with each other.

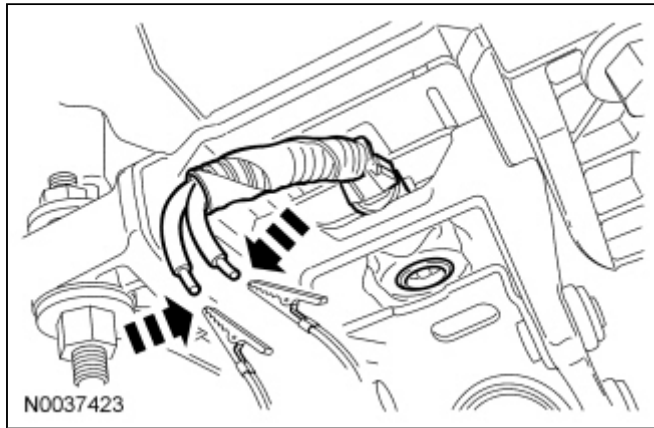

7. Remain at least 9.14 m (30 ft) away from the deployable steering column.
  8. From the end of the jumper harness that is not connected to the deployable steering column, disconnect the 2 wires of the jumper harness from each other.
  9. Deploy the deployable steering column by touching the ends of the 2 wires of the jumper harness to the terminals of a 12-volt battery.
  10. To allow for cooling, wait at least 10 minutes before approaching the deployed steering column.
  11. Dispose of the deployed steering column in the same manner as any other part to be scrapped.
-